

Low leakage current filter for the Japanese Market



- Designed for corner grounded delta networks (e.g. Japanese electric networks)
- Improvement of system reliability
- Two capacitors in series for high voltage tolerance to ground
- Industry standard form factor
- Lightweight EMC filter housing



Performance indicators

Attenuation performance



Rated current [A]

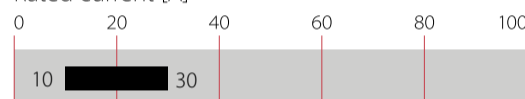

Technical Specifications

Operating voltage	530 / 305 VAC
Operating frequency	DC to 60 Hz
Rated currents	10 to 30 A @ 50°C
Overload capability	1.5 x rated current for 1 minute once per hour
High potential test voltage	2.28 kV DC 2s, phase to phase 2.5 kV AC 60s, phase to protected earth Repetition with max. 80% of the HV test voltage
Temperature range (operation and storage)	-40°C to +100°C (with derating >50°C)
Climatic category	40/100/21 (acc. IEC 60068-1)
Overvoltage category	III (acc. IEC 60664-1)
Pollution degree	PD2 (acc. IEC60664-1)
Protection category	IP 00 (acc. IEC 60529-1)
Surge withstand	2 kV, phase to phase (acc. to IEC 61000-4-5) 4 kV, phase to protected earth (acc. to IEC 61000-4-5)
Altitude	2000 m, current and voltage derating above
Design corresponding to	UL/IEC 60939-3 CSA C22.2 No. 8-13
Flammability according to	UL 94 V0
Vibration and shock	3M4 (acc. to IEC60721-3-3) Vibration: 10 to 55Hz, 2G, 3min, 1h each direction Shock: 20G, 11ms once each axis
MTBF	> 300'000 h

Approvals & Compliances



Features and Benefits

- A plastic housing combined with a metal ground plate achieve the lowest possible product weight without compromising EMC behaviour
- The embedded terminals from Schaffner guarantee user-friendly handling and reliable, long-lasting electrical connection
- fixed, hinged terminal covers contribute to overall safety by providing protection against unintended contact with live conductors. They are included in the standard scope of delivery without any extra cost
- Very low leakage current values make the filters suitable for grids with very tough requirements or sensitive GFCIs, and for applications which set value on safety and reliability
- FN3030 feature an ecologically conscious construction without the use of potting compound or banned substances (RoHS). Used raw materials can be easily separated at the end of the product life time for proper and environmentally safe disposal

Typical Applications

- Electrical and electronic equipment
- Test and measurement devices
- Medical devices & Industrial automation
- Small machines

Typical electrical schematic

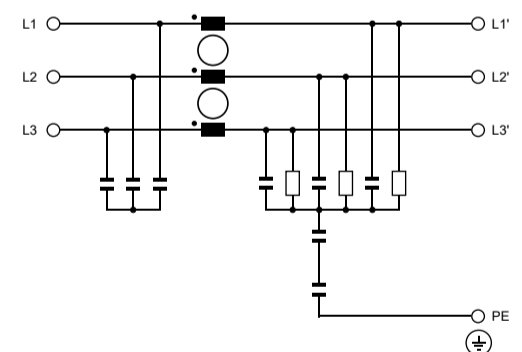

Filter Selection Table

Filter	Core*	Rated current		Leakage current**		Typical Power Loss****	Weight	Input/ Output connections
		@ 50°C	530 V/50 Hz	250 V/60 Hz*** corner grounded	@ 25°C			
		[A]	[mA]	[mA]	[W]			
Standard Housing								
FN3030-10-61-C00-R6	MnZn	10	0.00	0.0	6.0	0.45	-61	
FN3030-10-61-C12-R6	MnZn	10	0.01	0.3	6.0	0.45	-61	
FN3030-10-61-C18-R6	MnZn	10	0.07	1.8	6.0	0.45	-61	
FN3030-10-61-C20-R6	MnZn	10	0.14	4.0	6.0	0.45	-61	
FN3030-20-61-C00-R6	MnZn	20	0.00	0.0	8.4	0.45	-61	
FN3030-20-61-C12-R6	MnZn	20	0.01	0.3	8.4	0.45	-61	
FN3030-20-61-C18-R6	MnZn	20	0.07	1.8	8.4	0.45	-61	
FN3030-20-61-C20-R6	MnZn	20	0.14	4.0	8.4	0.45	-61	
FN3030-30-61-C00-R6	MnZn	30	0.00	0.0	9.5	0.45	-61	
FN3030-30-61-C12-R6	MnZn	30	0.01	0.3	9.5	0.45	-61	
FN3030-30-61-C18-R6	MnZn	30	0.07	1.8	9.5	0.45	-61	
FN3030-30-61-C20-R6	MnZn	30	0.14	4.0	9.5	0.45	-61	
FN3031-10-61-C20-R6	Nano	10	0.14	4.0	6.0	0.43	-61	
FN3031-20-61-C20-R6	Nano	20	0.14	4.0	8.4	0.43	-61	
FN3031-30-61-C20-R6	Nano	30	0.14	4.0	9.5	0.43	-61	
DIN Rail Housing								
FN3032-10-61-C00-R6	MnZn	10	0.00	0.0	6.0	0.50	-61	
FN3032-10-61-C12-R6	MnZn	10	0.01	0.3	6.0	0.50	-61	
FN3032-10-61-C18-R6	MnZn	10	0.07	1.8	6.0	0.50	-61	
FN3032-10-61-C20-R6	MnZn	10	0.14	4.0	6.0	0.50	-61	
FN3032-20-61-C00-R6	MnZn	20	0.00	0.0	8.4	0.50	-61	
FN3032-20-61-C12-R6	MnZn	20	0.01	0.3	8.4	0.50	-61	
FN3032-20-61-C18-R6	MnZn	20	0.07	1.8	8.4	0.50	-61	
FN3032-20-61-C20-R6	MnZn	20	0.14	4.0	8.4	0.50	-61	
FN3032-30-61-C00-R6	MnZn	30	0.00	0.0	9.5	0.50	-61	
FN3032-30-61-C12-R6	MnZn	30	0.01	0.3	9.5	0.50	-61	
FN3032-30-61-C18-R6	MnZn	30	0.07	1.8	9.5	0.50	-61	
FN3032-30-61-C20-R6	MnZn	30	0.14	4.0	9.5	0.50	-61	
FN3033-10-61-C20-R6	Nano	10	0.14	4.0	6.0	0.45	-61	
FN3033-20-61-C20-R6	Nano	20	0.14	4.0	8.4	0.45	-61	
FN3033-30-61-C20-R6	Nano	30	0.14	4.0	9.5	0.45	-61	

* Core material: MnZn: Ferrite core material / nano: Nanocrystalline core material

** Maximum leakage current under normal operating conditions (acc. to IEC60939-3).

*** Leakage current for delta network grids, with one corner grounded

**** Power Loss [W] calculated: $3 \cdot \text{RatedCurrent}^2 \cdot \text{Max.DCRes}$

Product Selector

FN30vx-yy-Czz-R6

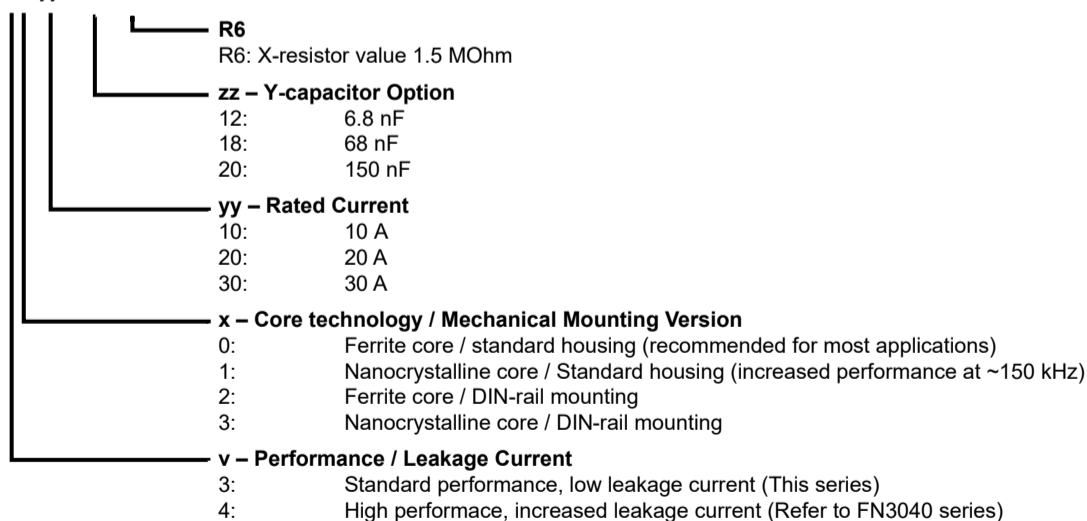

Typical Filter Attenuation

Per CISPR 17; A=50 Ω/50 Ω sym; B=50 Ω/50 Ω asym

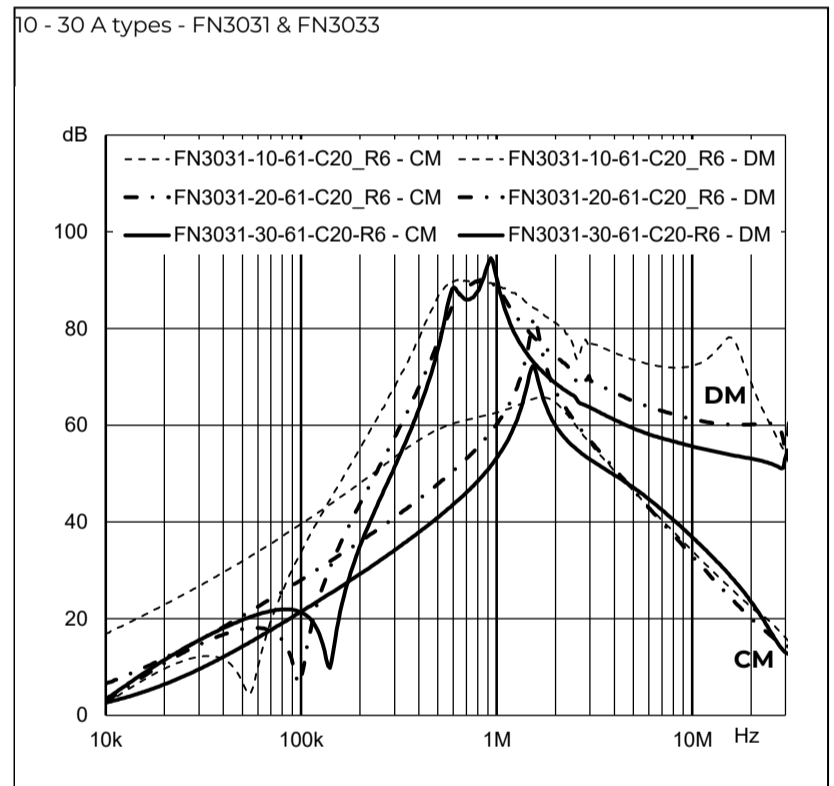
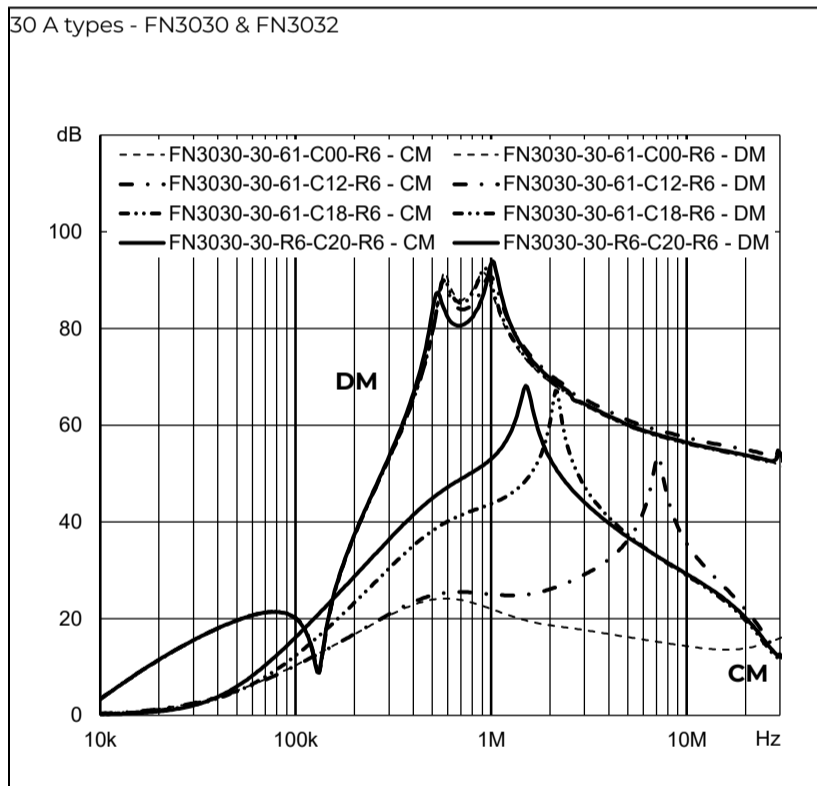
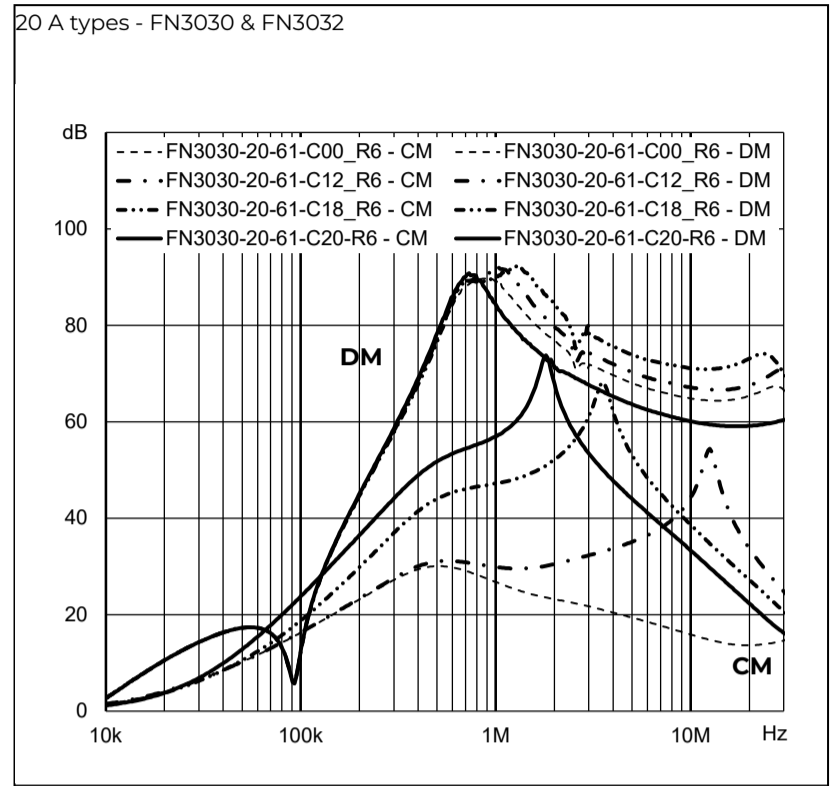
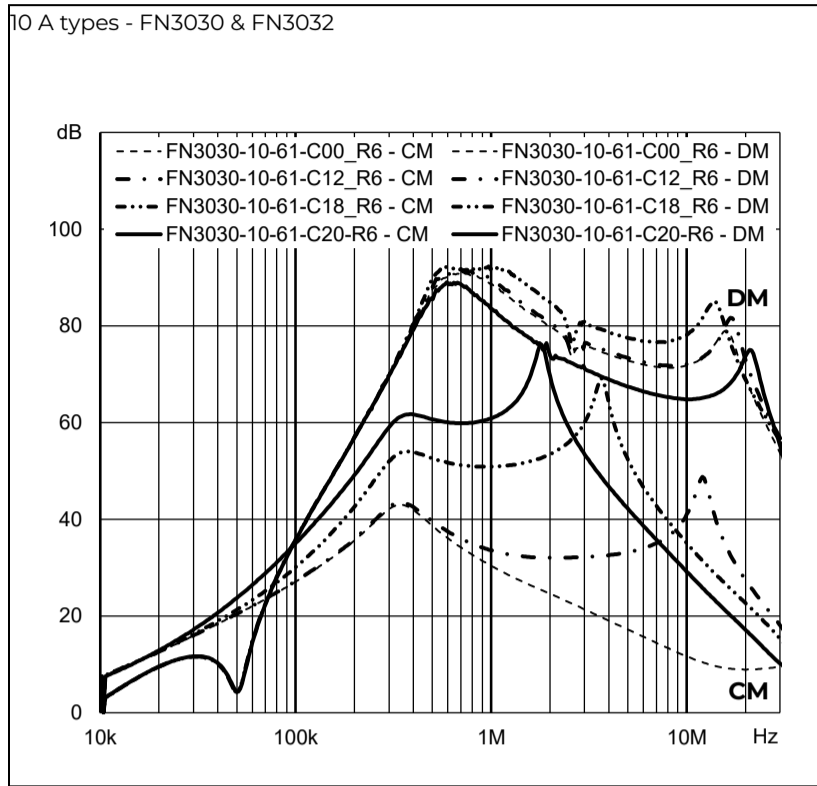

Filter Input/Output Connector Cross Sections

	-61 (10 A)	-61 (20 A)	-61 (30 A)
Ring/fork lug (W/d)*	max. 11 mm/min. Ø 4.3 mm	max. 11 mm/min. Ø 4.3 mm	max. 11 mm/min. Ø 4.3 mm
Recommended torque	1.2 - 1.4 Nm	1.2 - 1.4 Nm	1.2 - 1.4 Nm

* Schaffner recommends the use of insulated and UL-recognized ring lugs or fork lugs of the appropriate size.

Mechanical Data

Chassis Mounting FN3030 & FN3031

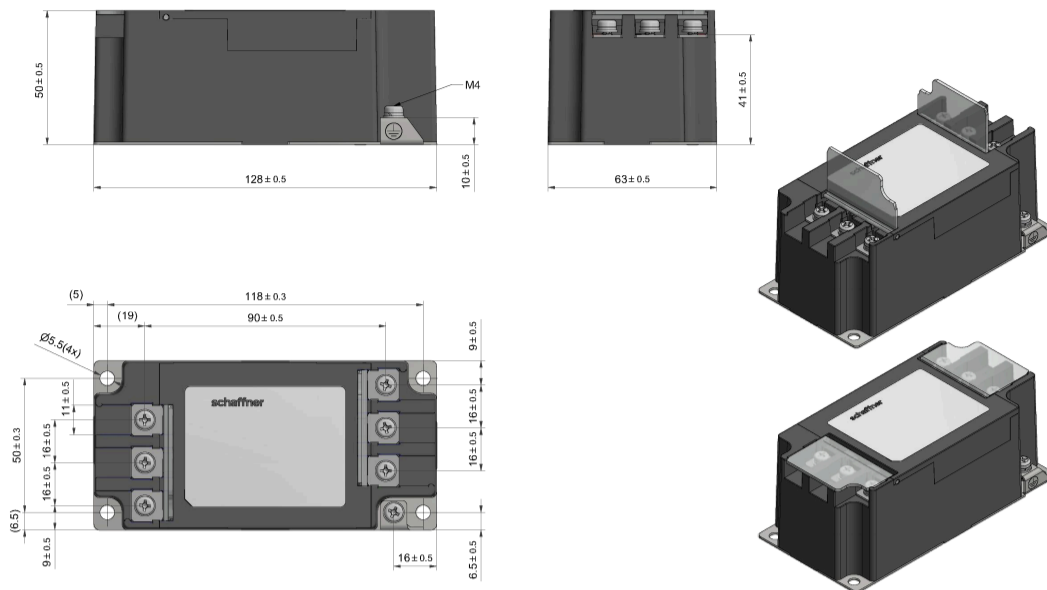

DIN Rail Mounting FN3032 & FN3033

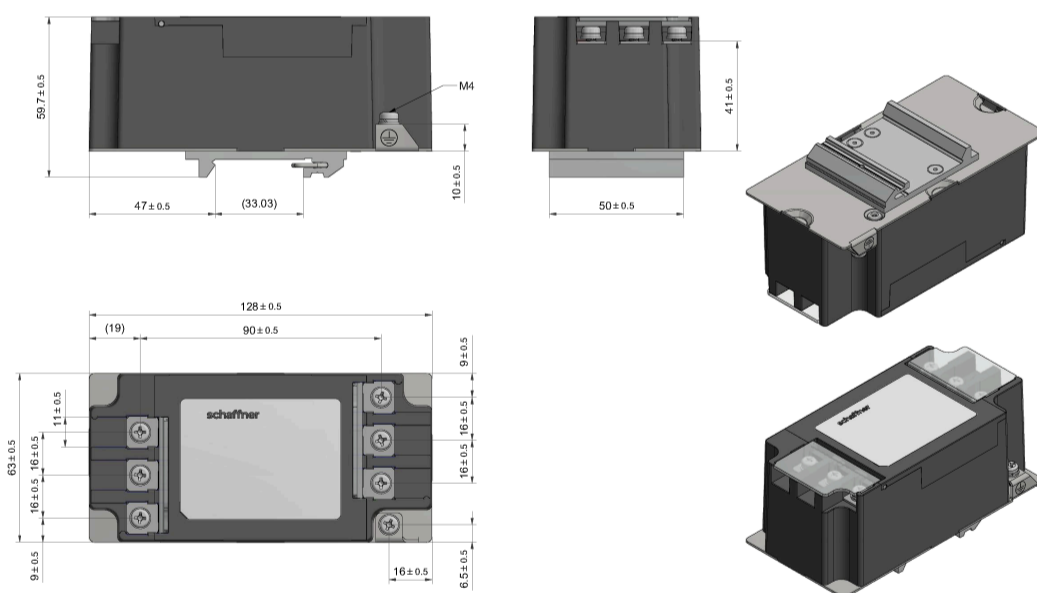

All dimensions in mm. For dimensions without stated tolerances: ISO 2768-m/EN 22768-m
Recommended torque PE: 1.2 - 1.4 Nm

Headquarters, Global Innovation and Development

Switzerland

Schaffner Group
Industrie Nord
Nordstrasse 11e
4542
Luterbach
+41 32 681 66 26
info@schaffner.com

Sales and Application Centers

Finland

Schaffner Oy
Lohjanharjuntie 1109
8500
Lohja
+358 50 468 7284
finlandsales@schaffner.com

France

Schaffner EMC S.A.S.
16-20 Rue Louis Rameau
95875
Bezons
+33 1 34 34 30 60
francesales@schaffner.com

Germany

Schaffner Deutschland GmbH
Schoemperlenstrasse 12B
76185
Karlsruhe
+49 721 56910
germanysales@schaffner.com

India

Schaffner India Pvt. Ltd
Regus World Trade Centre
WTC 22nd Floor Unit No 2238 Brigade
Gateway Campus 26/1 Dr. Rajkumar Road
Malleshwaram (W)
560055
Bangalore
+91 8067935355
indiasales@schaffner.com

United Kingdom

Schaffner Ltd.
Suite 1 Oakmede Place
Terrace Road
RG42 4JF
Binfield
+44 118 9770070
uksales@schaffner.com

Singapore

Schaffner EMC Pte Ltd.
Blk 3015A Ubi Road 1 #05-09 Kampong Ubi
Industrial Estate
408705
Singapore
+65 63773283
singaporesales@schaffner.com

Sweden

Schaffner EMC AB
Östermalmstrorg 1
114 42
Stockholm
+46 8 5050 2425
swedensales@schaffner.com

Switzerland

Schaffner EMV AG
Industrie Nord
Nordstrasse 11e
4542
Luterbach
+41 32 681 66 26
switzerlandsales@schaffner.com

Taiwan

Schaffner EMV Ltd.
U-Town
20 Floor-2 No 97 Section 1 XinTai 5th Road
XiZhi District
22175
New Taipei City
+886 226975500
taiwansales@schaffner.com

Italy

Schaffner EMC S.r.l.
Via Ticino, 30
20900
Monza (MB)
+39 039 21 41 070
italysales@schaffner.com

United States

Schaffner EMC Inc.
52 Mayfield Avenue
Edison, New Jersey
+1 732 225 9533
usasales@schaffner.com

Japan

Schaffner EMC K.K.
ISM Sangenjaya
7F 1-32-12 Kamiuma Setagaya-ku
154-0011
Tokyo
+81 3 5712 3650
japansales@schaffner.com

To find your local partner within
Schaffner's global network schaffner.com

© 2023 Schaffner Group

The content of this document has been carefully checked and understood. However, neither Schaffner nor its subsidiaries assume any liability whatsoever for any errors or inaccuracies of this document and the consequences thereof. Published specifications are subject to change without notice. Product suitability for any area of application must ultimately be determined by the customer. In all cases, products must never be operated outside their published specifications. Schaffner does not guarantee the availability of all published products. This disclaimer shall be governed by substantive Swiss law and resulting disputes shall be settled by the courts at the place of business of Schaffner Holding AG. Latest publications and a complete disclaimer can be downloaded from the Schaffner website. All trademarks recognized.